

INSTRUCTION SHEET

OFF VEHICLE CARBURETOR SERVICE

ROCHESTER — MODEL 2G, 2GC

50-506-6

GENERAL EXPLODED VIEW

THE GENERAL DESIGN AND PARTS SHOWN WILL VARY TO
INDIVIDUAL UNITS COVERED ON THIS INSTRUCTION SHEET

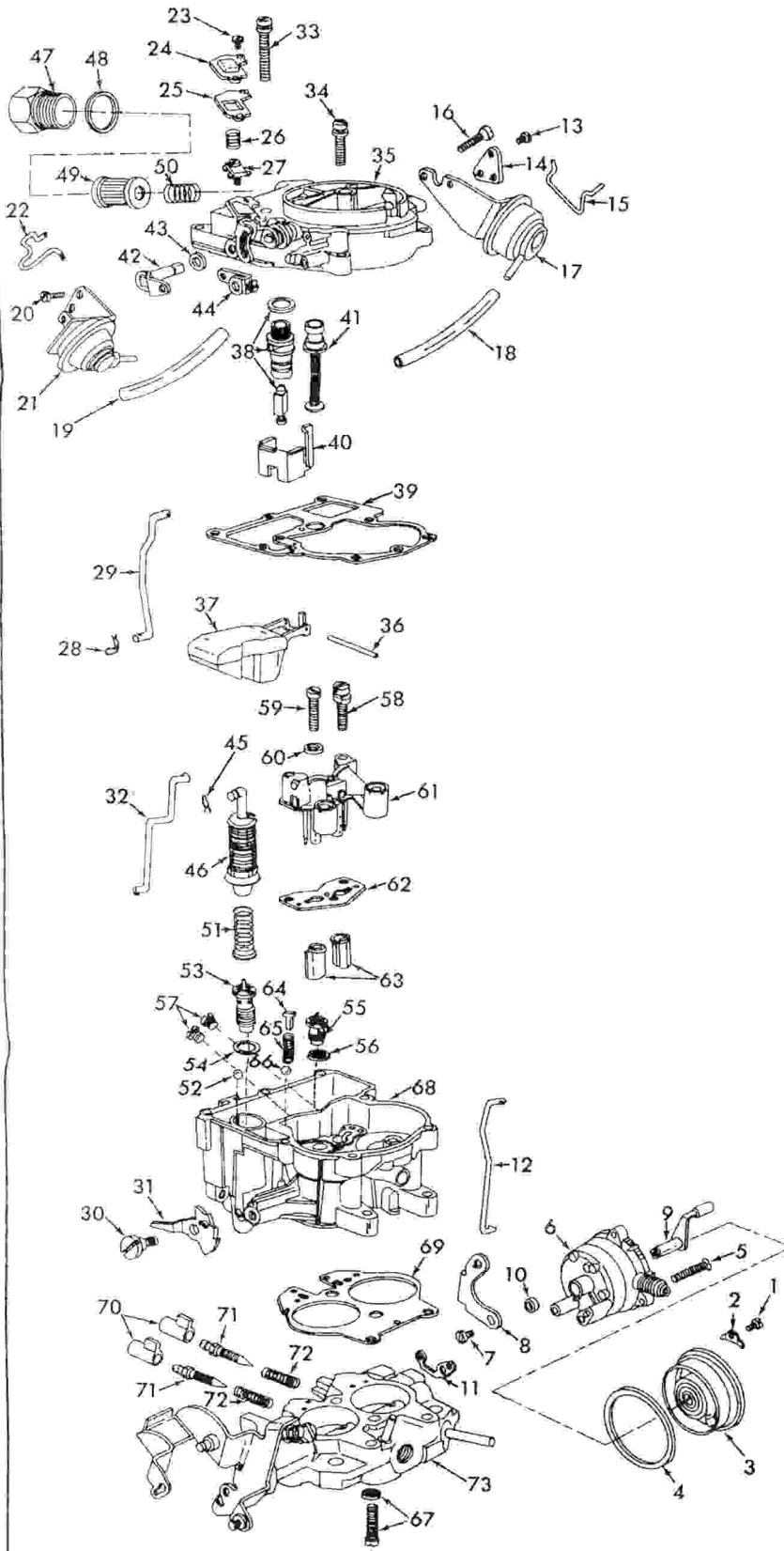

DISASSEMBLY

USE EXPLODED VIEW AS A GUIDE. THE NUMERICAL SEQUENCE MAY GENERALLY BE FOLLOWED TO DISASSEMBLE UNIT FAR ENOUGH TO PERMIT CLEANING AND INSPECTION. NOTE TO REMOVE PUMP ASSY. (46), TWIST UPSET END WITH SMALL PLIERS UNTIL IT BREAKS OFF. SERVICE PUMP WILL HAVE A RETAINING CLIP GROOVE. REMOVE STAKING FROM BOWL COVER FOR EASY REMOVAL OF POWER PISTON ASSEMBLY (41). IDLE LIMITER CAPS (70) CAN EASILY BE REMOVED BY BREAKING OFF WITH A PAIR OF PLIERS. NO REPLACEMENT CAPS ARE NECESSARY AS A BARE MIXTURE SCREW IS SUFFICIENT TO INDICATE THAT THE MIXTURE HAS BEEN READJUSTED. BEFORE REMOVING IDLE ADJUSTING NEEDLES (71), TURN IN TO COUNT THE NUMBER OF TURNS NEEDLES ARE OUT FROM A SEATED POSITION. SOME MODELS IN 1980-81 WILL HAVE A PUMP LEVER SHAFT SEAL. USE A SMALL SCREW DRIVER TO PRY OUT THE OLD SEAL. AFTER CLEANING INSTALL NEW SEAL WITH THE LIP OF SEAL FACING OUTWARD.

NOMENCLATURE

REF. NO.	REF. NO.
1. SCREW (3)-CHOKE COVER RETAINER	35. BOWL COVER ASSY.
2. RETAINER (3)-CHOKE COVER	36. PIN - FLOAT HINGE
3. CHOKE COVER & SPRING ASSY.	37. FLOAT & LEVER ASSY.
4. GASKET - CHOKE COVER	38. NEEDLE, SEAT & GASKET ASSY.
5. SCREW (2)-CHOKE HOUSING	39. GASKET-BOWL COVER
6. CHOKE HOUSING ASSY.	40. BAFFLE - FUEL
7. SCREW - LEVER	41. POWER PISTON ASSY.
8. LEVER-INTERMEDIATE CHOKE	42. PUMP LEVER SHAFT
9. SHAFT ASSY.-INTERMEDIATE CHOKE	43. WASHER-PUMP SHAFT (NYLON)
10. SEAL-INTERMEDIATE CHOKE SHAFT	44. LEVER - INNER PUMP
11. GASKET - CHOKE HOUSING	45. RETAINER (SERVICE ITEM)
12. ROD-INTERMEDIATE CHOKE	46. PUMP ASSY.
13. SCREW-CHOKE SHAFT LEVER	47. FITTING - FUEL INLET
14. LEVER - CHOKE SHAFT	48. GASKET - FITTING
15. LINK-AUX. VACUUM BREAK	49. FILTER - FUEL
16. SCREW (2)-AUX. VACUUM BREAK	50. SPRING - FUEL FILTER
17. AUXILIARY VACUUM BREAK ASSY.	51. SPRING - PUMP RETURN
18. HOSE-AUX. VAC. BREAK	52. BALL-PUMP INTAKE CHECK (ALUM)
19. HOSE-PRI. VAC. BREAK	53. POWER VALVE ASSY.-MECH.
20. SCREW (2)-PRI. VAC. BREAK	54. GASKET - POWER VALVE
21. PRIMARY VACUUM BREAK ASSY.	55. POWER VALVE ASSY.-VAC.
22. LINK-PRI. VAC. BREAK	56. GASKET-POWER VALVE
23. SCREW (2)-VENT COVER	57. JET (2) - MAIN
24. COVER - VENT VALVE	58. SCREW & LOCKWASHER (7)-VENTURI CLUSTER
25. GASKET - VENT COVER	59. SCREW-VENTURI CLUSTER CENTER
26. SPRING - VENT VALVE	60. GASKET - CENTER SCREW
27. VENT VALVE ASSY.	61. VENTURI CLUSTER ASSY.
28. RETAINER - PUMP ROD	62. GASKET-VENTURI CLUSTER
29. ROD - PUMP	63. INSERT (2)-MAIN WELL
30. SCREW - FAST IDLE CAM	64. GUIDE-PUMP DISC. SPRING
31. CAM - FAST IDLE	65. SPRING-PUMP DISC. BALL
32. ROD - CHOKE	66. BALL-PUMP DISC. (STEEL)
33. SCREW & LOCKWASHER (1)-BOWL COVER (LONG)	67. SCREW & LOCKWASHER (3)-THROTTLE BODY
34. SCREW & LOCKWASHER (7)-BOWL COVER	68. BOWL ASSY.
	69. GASKET-THROTTLE BODY
	70. CAP (2)-IDLE LIMITER
	71. NEEDLE (2)-IDLE ADJUSTING
	72. SPRING (2)-IDLE ADJ. NEEDLE
	73. THROTTLE BODY ASSY.

CLEANING

CLEANING MUST BE DONE WITH CARBURETOR DISASSEMBLED. USE A CARBURETOR CLEANING SOLVENT TO SOAK PARTS LONG ENOUGH TO SOFTEN AND REMOVE ALL FOREIGN MATERIAL. MAKE CERTAIN THE THROTTLE BORES ARE FREE OF ALL CARBON AND VARNISH DEPOSITS. RINSE OFF IN SUITABLE SOLVENT. BLOW OUT ALL PASSAGES IN CASTINGS WITH COMPRESSED AIR AND CHECK CAREFULLY TO INSURE THOROUGH CLEANING OF OBSCURE AREAS. CAUTION: DO NOT SOAK FLOAT, DIAPHRAGM UNITS, RUBBER OR PLASTIC PARTS IN SOLVENT. DO NOT SAND, WIRE BRUSH, OR FILE ON TEFLON-COATED PARTS.

REASSEMBLY

REASSEMBLE IN REVERSE ORDER OF DISASSEMBLY. NOTE SPECIAL INSTRUCTIONS AND FOLLOW NUMERICAL OUTLINE IN MAKING ADJUSTMENTS NECESSARY FOR CARBURETOR BEING SERVICED.

SPECIAL INSTRUCTIONS

IDLE ADJUSTING NEEDLES (71) - TURN EACH NEEDLE IN UNTIL LIGHTLY SEATED, THEN BACK OUT NUMBER OF TURNS COUNTED ON DISASSEMBLY.

PUMP RETURN SPRING (51) - INSTALL WITH LARGE END TO BOTTOM OF PUMP WELL.

POWER PISTON ASSY. (41) - LIGHTLY STAKE CASTING AROUND WASHER.

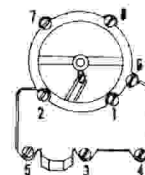

AIR HORN TIGHTENING SEQUENCE

INTERMEDIATE CHOKE SHAFT SEAL (10) - INSTALL SEAL WITH LIP FACING OUT.

CHOKE COVER GASKET (4) - DO NOT USE WITH ELECTRIC CHOKE COVER, IT MUST BE GROUNDED.

ADJUSTMENTS

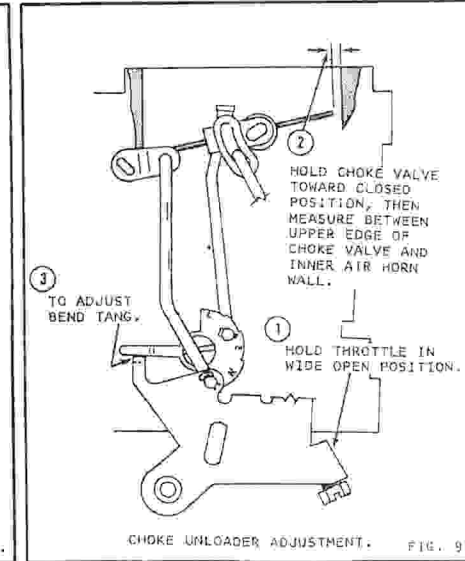
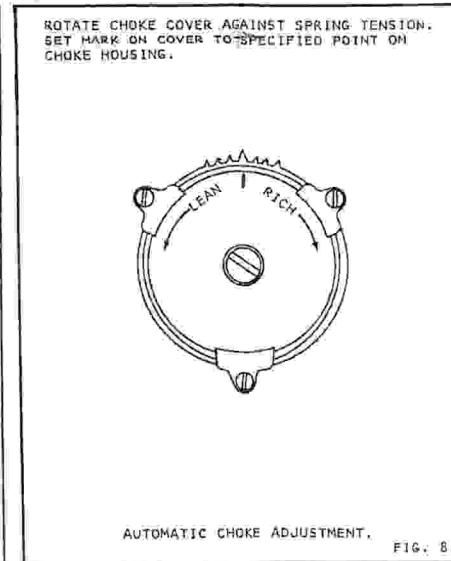
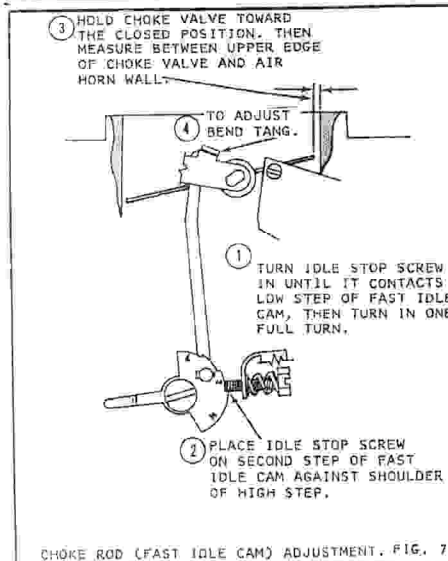
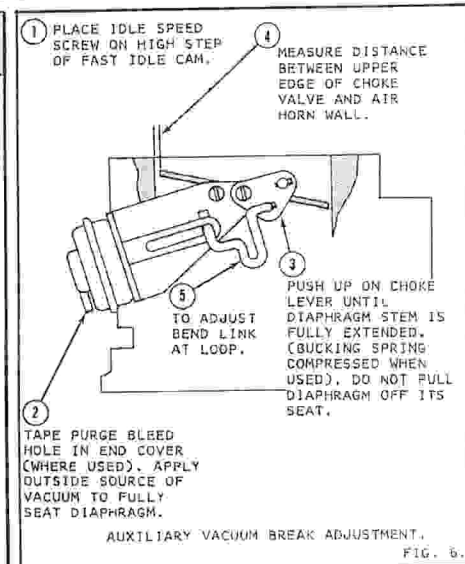
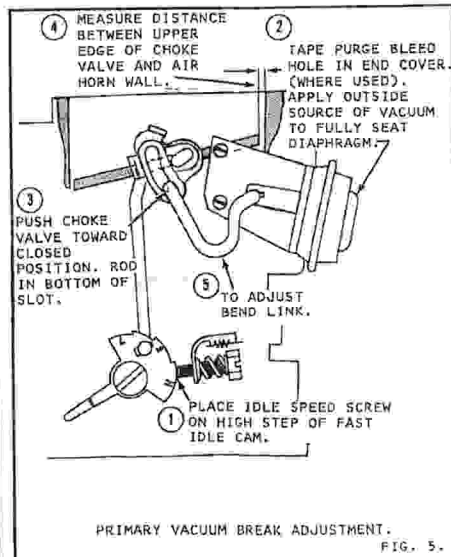
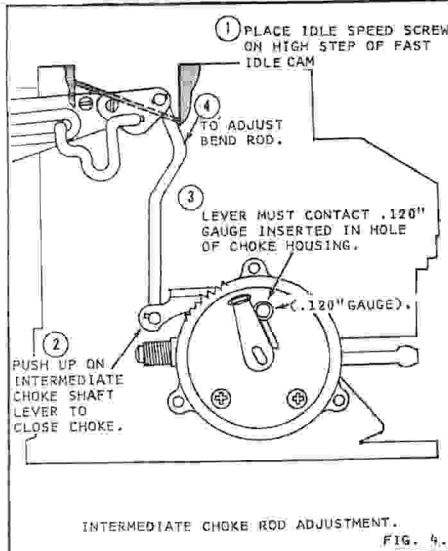
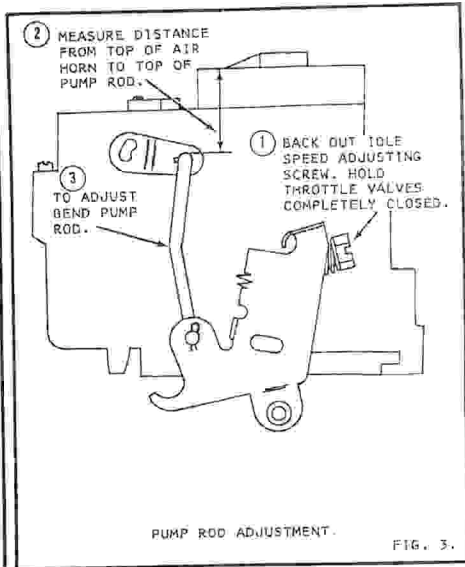
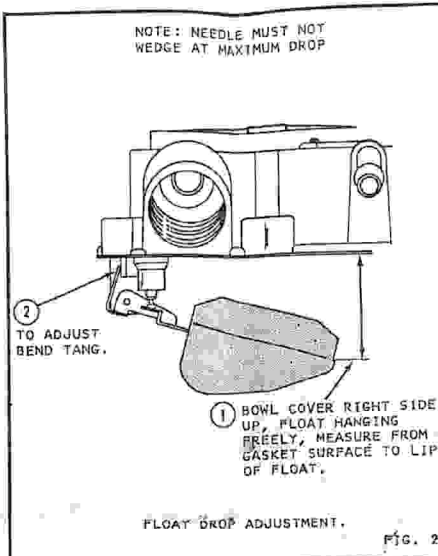
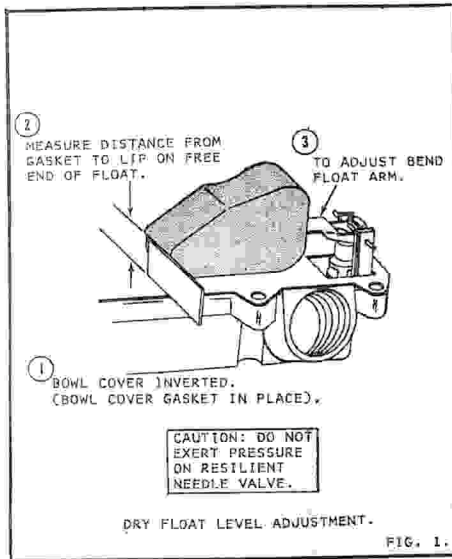

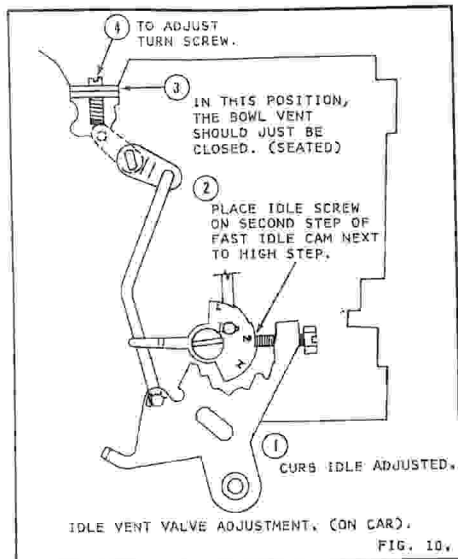

ADJUSTMENT DATA TABLE ROCHESTER CARBURETOR MODEL 2GC

Year	Make		Float Level	Float Drop	Pump Rod Setting	Primary Vacuum Break	Auxiliary Vacuum Break	Choke Rod	Unloader	Automatic Choke Setting	
1975	Buick 231" Eng. V6 Carb. No. 7045145 Carb. No. 7045147 Calif. 350" Eng. V8	A/T	7/16"	1 9/32"	1 19/32"	1/8"	1/8"	5/64"	9/64"	1-RICH	
		M/T	7/16"	1 9/32"	1 19/32"	3/16"	1/8"	5/64"	9/64"	1-LEAN	
		M/T	7/16"	1 9/32"	1 19/32"	1/8"	1/8"	5/64"	9/64"	1-LEAN	
		A/T	7/16"	1 9/32"	1 19/32"	1/8"	1/8"	5/64"	9/64"	1-LEAN	
		A/T	15/32"	1 9/32"	1 19/32"	9/64"	1/8"	5/64"	3/16"	1-RICH	
1976	Buick 231" Eng. V6 350" Eng. V8	Federal	7/16"	1 5/32"	1 19/32"	7/64"	3/32"	5/64"	9/64"	1-RICH	
		Calif.	7/16"	1 5/32"	1 19/32"	1/8"	7/64"	5/64"	9/64"	1-RICH	
		A/T	15/32"	1 5/32"	1 11/32"	9/64"	3/32"	5/64"	3/16"	1-RICH	
1977	Buick 231" Eng. V6 Carb. No. 17057141, 7145, 7147 Calif. Calif. Altitude Buick 350" Eng. V8	Federal	7/16"	1 5/32"	1 17/32"	7/64"	3/64"	5/64"	9/64"	3-RICH	
		A/T	7/16"	1 5/32"	1 1/2"	7/64"	3/64"	5/64"	9/64"	1-RICH	
		A/T	7/16"	1 5/32"	1 1/2"	1/8"	7/64"	5/64"	9/64"	1-RICH	
		M/T	7/16"	1 5/32"	1 1/2"	9/64"	7/64"	5/64"	9/64"	INDEX	
		A/T	7/16"	1 5/32"	1 17/32"	1/8"	7/64"	5/64"	9/64"	1-RICH	
1978	Buick 196" Eng. V6 Buick 231" Eng. V6 Calif. Carb. No. 17058444 17058446 17058448 Calif. Altitude	Federal	7/16"	1 5/32"	1 19/32"	1/8"	3/64"	5/64"	9/64"	1-RICH	
		M/T	7/16"	1 5/32"	1 9/16"	7/64"	5/64"	5/64"	9/64"	1-RICH	
		A/T	7/16"	1 5/32"	1 19/32"	7/64"	5/64"	5/64"	9/64"	1-RICH	
		Federal/Can.	7/16"	1 5/32"	1 19/32"	7/64"	1/16"	5/64"	5/32"	1-RICH	
		Federal	M/T	7/16"	1 5/32"	1 19/32"	7/64"	1/16"	5/64"	5/32"	1-RICH
		A/T	7/16"	1 5/32"	1 19/32"	9/64"	3/32"	5/64"	9/64"	1-RICH	
		A/T	7/16"	1 5/32"	1 19/32"	1/8"	7/64"	5/64"	9/64"	1-RICH	
		A/T	7/16"	1 5/32"	1 9/16"	9/64"	3/32"	5/64"	9/64"	1-RICH	
		M/T	7/16"	1 5/32"	1 19/32"	5/32"	7/64"	5/64"	9/64"	1-RICH	
All/T	7/16"	1 5/32"	1 19/32"	9/64"	3/32"	5/64"	9/64"	1-RICH			
1978	Chevrolet 196" Eng. V6 Chevrolet 231" Eng. V6 Federal/Can. Federal Calif. M/T Altitude	A/T	7/16"	1 5/32"	1 5/8"	7/64"	1/16"	5/64"	9/64"	1-RICH	
		M/T	7/16"	1 5/32"	1 9/16"	7/64"	5/64"	5/64"	9/64"	1-RICH	
		A/T	7/16"	1 5/32"	1 19/32"	7/64"	5/64"	5/64"	9/64"	1-RICH	
		Federal/Can.	A/T	7/16"	1 5/32"	1 19/32"	7/64"	5/64"	5/64"	9/64"	1-RICH
		Federal	M/T	7/16"	1 5/32"	1 19/32"	7/64"	1/16"	5/64"	5/32"	1-RICH
		Calif.	A/T	7/16"	1 5/32"	1 9/16"	9/64"	3/32"	5/64"	9/64"	1-RICH
1979-81	Chevrolet & GMC Truck 350" Eng. V8 Fed. Calif. Fed. Calif. W/VAC.Gov. Fed. Calif. W/VAC. Gov. Carb. No. 17080129	A/T	5/8"	1 9/32"	1 21/32"	—	—	—	—	—	
		All/T	17/32"	1 9/32"	1 15/32"	—	—	—	—	—	
		All/T	5/8"	1 9/32"	1 15/32"	—	—	—	—	—	
		All/T	5/8"	1 9/32"	1 21/32"	—	—	—	—	—	
		All/T	5/8"	1 9/32"	1 21/32"	—	.130	.245	.250	—	

Year	Make		Float Level	Float Drop	Pump Rod Setting	Primary Vacuum Break	Auxiliary Vacuum Break	Choke Rod	Unloader	Automatic Choke Setting
1975	Oldsmobile 231" Eng. V6 350" Eng. V8	A/T	7/16"	1 9/32"	1 19/32"	1/8"	1/8"	5/64"	9/64"	1-RICH
		M/T	7/16"	1 9/32"	1 19/32"	1/8"	1/8"	5/64"	9/64"	1-LEAN
1976	Oldsmobile 231" Eng. V6 Carb. No. 7045147, 449 7045149 7045441 7045447 17056145, 6149 17056447, 6449	A/T	7/16"	1 9/32"	1 19/32"	1/8"	1/8"	5/64"	9/64"	1-LEAN
		A/T	7/16"	1 7/32"	1 19/32"	1/8"	7/64"	5/64"	3/16"	1-RICH
		M/T	7/16"	1 9/32"	1 19/32"	1/8"	1/8"	37/64"	9/64"	1-LEAN
			7/16"	1 5/32"	1 19/32"	7/64"	3/32"	5/64"	9/64"	1-RICH
			7/16"	1 5/32"	1 19/32"	1/8"	7/64"	5/64"	9/64"	1-RICH
			7/16"	1 5/32"	1 19/32"	1/8"	7/64"	5/64"	9/64"	1-RICH
1976	Oldsmobile 350" Eng. V8 Carb. No. 17056143 17056144	A/T	15/32"	1 5/32"	1 9/16"	9/64"	7/64"	5/64"	3/16"	1-RICH
		A/T	15/32"	1 5/32"	1 5/8"	3/16"	1/32"	5/64"	3/16"	1-RICH
1977	Oldsmobile 231" Eng. V6 Federal Calif. Calif. Altitude	A/T	7/16"	1 5/32"	1 17/32"	7/64"	3/64"	5/64"	9/64"	3-RICH
		M/T	7/16"	1 5/32"	1 1/2"	7/64"	3/64"	5/64"	9/64"	1-RICH
		A/T	7/16"	1 5/32"	1 1/2"	1/8"	7/64"	5/64"	9/64"	1-RICH
		M/T	7/16"	1 5/32"	1 1/2"	9/64"	7/64"	5/64"	9/64"	INDEX
		A/T	7/16"	1 5/32"	1 17/32"	1/8"	7/64"	5/64"	9/64"	1-RICH
1978	Oldsmobile 231" Eng. V6 Federal/Can. Federal Calif. Carb. No. 17058444 17058446 17058448 Calif. Altitude	A/T	7/16"	1 5/32"	1 19/32"	7/64"	5/64"	5/64"	9/64"	1-RICH
		M/T	7/16"	1 5/32"	1 19/32"	7/64"	1/16"	5/64"	5/32"	1-RICH
		A/T	7/16"	1 5/32"	1 19/32"	9/64"	3/32"	5/64"	9/64"	1-RICH
		A/T	7/16"	1 5/32"	1 19/32"	1/8"	7/64"	5/64"	9/64"	1-RICH
		A/T	7/16"	1 5/32"	1 9/16"	9/64"	3/32"	5/64"	9/64"	1-RICH
		M/T	7/16"	1 5/32"	1 19/32"	5/32"	7/64"	5/64"	9/64"	1-RICH
		All/T	7/16"	1 5/32"	1 19/32"	9/64"	3/32"	5/64"	9/64"	1-RICH
			7/16"	1 5/32"	1 19/32"	9/64"	3/32"	5/64"	9/64"	1-RICH
1975	Pontiac 350" Eng. V8 Carb. No. 7045143 400" Eng. V8	A/T	9/16"	1 7/32"	1 9/32"	9/64"	17/64"	3/32"	3/16"	1-RICH
		A/T	15/32"	1 9/32"	1 19/32"	9/64"	1/8"	5/64"	3/16"	1-RICH
		A/T	9/16"	1 7/32"	1 11/32"	9/64"	17/64"	3/32"	3/16"	1-RICH
1976	Pontiac 231" Eng. V6 Federal Calif.	A/T	7/16"	1 5/32"	1 19/32"	7/64"	3/32"	5/64"	9/64"	1-RICH
		A/T	7/16"	1 5/32"	1 19/32"	1/8"	7/64"	5/64"	9/64"	1-RICH
1976	Pontiac 350" Eng. V8 Carb. No. 17056143 7045163, 5173 17056161, 6162 17056163 17056144 Pontiac 400" Eng. V8 Carb. No. 7045167 17056160, 17056164	A/T	15/32"	1 5/32"	1 9/16"	9/64"	7/64"	5/64"	3/16"	1-RICH
		A/T	9/16"	1 7/32"	1 11/32"	9/64"	17/64"	3/32"	3/16"	1-RICH
		A/T	9/16"	1 9/32"	1 11/32"	11/64"	9/32"	3/32"	3/16"	1-RICH
		A/T	9/16"	1 9/32"	1 11/32"	9/64"	9/32"	3/32"	3/16"	1-RICH
		A/T	15/32"	1 5/32"	1 5/8"	3/16"	1/32"	5/64"	3/16"	1-RICH
		A/T	9/16"	1 7/32"	1 5/16"	9/64"	5/16"	3/32"	3/16"	1-RICH
		A/T	9/16"	1 9/32"	1 11/32"	11/64"	9/32"	3/32"	3/16"	1-RICH
1977	Pontiac 231" Eng. V6 Federal Calif. Calif. Altitude	A/T	7/16"	1 5/32"	1 17/32"	7/64"	3/64"	5/64"	9/64"	3-RICH
		M/T	7/16"	1 5/32"	1 1/2"	7/64"	3/64"	5/64"	9/64"	1-RICH
		A/T	7/16"	1 5/32"	1 1/2"	1/8"	7/64"	5/64"	9/64"	1-RICH
		M/T	7/16"	1 5/32"	1 1/2"	9/64"	7/64"	5/64"	9/64"	INDEX
		A/T	7/16"	1 5/32"	1 17/32"	1/8"	7/64"	5/64"	9/64"	1-RICH
1978	Pontiac 231" Eng. V6 Federal/Can. Federal Calif. Carb. No. 17058444 17058446 17058448 Calif. Altitude	A/T	7/16"	1 5/32"	1 19/32"	7/64"	5/64"	5/64"	9/64"	1-RICH
		M/T	7/16"	1 5/32"	1 19/32"	7/64"	1/16"	5/64"	5/32"	1-RICH
		A/T	7/16"	1 5/32"	1 19/32"	9/64"	3/32"	5/64"	9/64"	1-RICH
		A/T	7/16"	1 5/32"	1 19/32"	1/8"	7/64"	5/64"	9/64"	1-RICH
		A/T	7/16"	1 5/32"	1 9/16"	9/64"	3/32"	5/64"	9/64"	1-RICH
		M/T	7/16"	1 5/32"	1 19/32"	5/32"	7/64"	5/64"	9/64"	1-RICH
		All/T	7/16"	1 5/32"	1 19/32"	9/64"	3/32"	5/64"	9/64"	1-RICH