

HOLLEY 4-BARREL CARBURETOR

Slight variations between carburetors in this group will occur, though basically all units are alike. (See reverse side for reference numbers.)

I. DISASSEMBLY.

Remove all parts in the order of index numbers on reverse side. Pay particular attention to the following:

- a. After prying out retainer (28), tip body (42) to drop out needle (31), nozzles (30) and ball (29).
- b. Push out lubricator (64) and ring (65) with a wood dowel or similar tool.
- c. After removing retainers (59), tip throttle body (86) to drop out balls (60).
- d. To remove "O" rings (16 and 62), pry out washers (15 and 61). These washers are staked in place.
- e. When removing ball retainer (68), catch the ball, which is used in standard transmission models.

II. CLEANING.

Soak parts long enough to soften and remove all foreign material. Use 1) a regular carburetor cleaning solvent; 2) lacquer thinner; or 3) denatured alcohol. Use a small brush to aid cleaning, if necessary. Make certain the throttle body is free of all hard carbon deposits. Blow out all passages in castings with compressed air, and check carefully to insure thorough cleaning of obscure areas.

III. REASSEMBLY.

Assemble carburetor in reverse of index numbers on opposite side. Give special attention to the following:

- a. Install a check ball in passage above retainer (68) on standard transmission models.
- b. Make sure secondary throttle valves are closed fully before tightening screws (74) in cover (75) to insure proper flexing of diaphragm (77).
- c. Before installing cover (70), see that secondary throttle linkage does not bind.
- d. Push ring (65) and washer (64) into recess of main body (42) and saturate with oil before installing pump rod (23).
- e. When installing float (26), make sure spring (27) is over the projection in body (42) and through hole in lever of float (26).
- f. Make sure the clip on needle (34) is hooked on the lever of float (26), and that no binding is present.
- g. After installing check ball (29) and retainer (28), shake body (42) to make sure ball is free. Also shake throttle body after installing ball (60) and retainer (59).
- h. After installing "O" rings (16 and 62), press washers

(15 and 61) into recesses and stake lightly in place with the tip of a screwdriver. Dip all "O" rings in oil before installation.

i. When installing diaphragm assembly (14), start screw (12) and jets (11) into place and run them down far enough to hold the diaphragm flat but allow it to slip. Then press the diaphragm stem all the way in and tighten the screw (12) and secondary jets (11) to insure proper flexing of the diaphragm.

j. When installing idle needles (66) and springs (67), turn each needle down on seat lightly, then back it out one turn.

k. When installing the fuel inlet fitting (51), slide open end of the screen (53) on the fitting (51) to avoid damaging screen (53).

l. When installing air horn (49), make sure locating pin is in hole of throttle body (86).

m. The air horn seal (50) should be cemented in the groove of air horn (49) with a small amount of gasket cement.

n. Make sure the stem of dashpot (85) is aligned with screw in throttle lever. Bend bracket (82), if necessary.

o. Connect pump link (19) in middle hole of throttle lever.

p. Install bowl vent selector (63) over lower vent hole in pump rod (23) for winter setting; uncover hole for summer.

IV. FLOAT SETTING. (See figure 1.)

Apply finger pressure to the float lip to close needle valve in seat. Place the gage included in kit over the edge of main body and adjust float height until the gage just touches top surface of float at location farthest from needle valve. Adjust by bending float lip only. If both floats are not the same height, bend float lever slightly.

V. IDLE ADJUSTMENT. (See figure 2.)

Install carburetor, run engine until hot, then set throttle stop screw (1) to produce an idle speed of 450-500 rpm. Rotate idle adjusting needles (2) to produce a smooth idle response. It may be necessary to adjust screws (1 and 2) alternately until the proper idle response is obtained at correct idle speed.

VI. DASHPOT ADJUSTMENT. (See figure 3.)

- a. Adjust engine idle as described in paragraph V.
- b. With engine idling, press dashpot stem all the way in. While holding it in this position rotate dashpot adjusting screw to provide a clearance of .050 inch at end of stem.

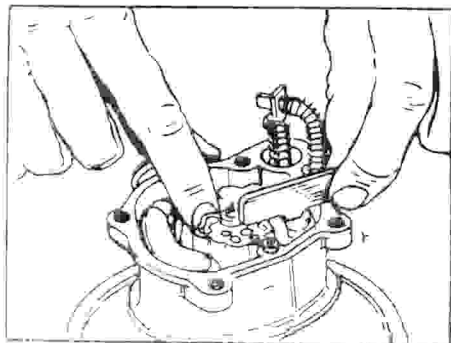

Figure 1

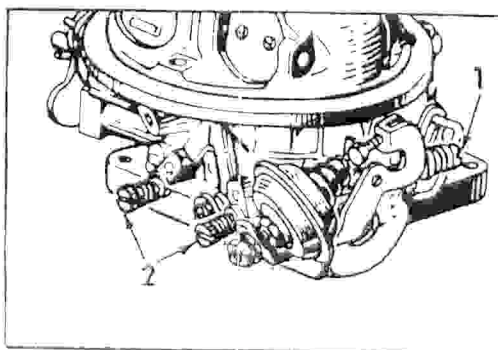

Figure 2

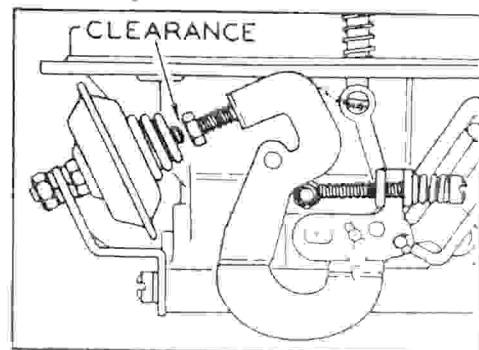

Figure 3

# PARTS LIST

## HOLLEY 4-BARREL CARBURETOR

REF.  
NO.

NOMENCLATURE

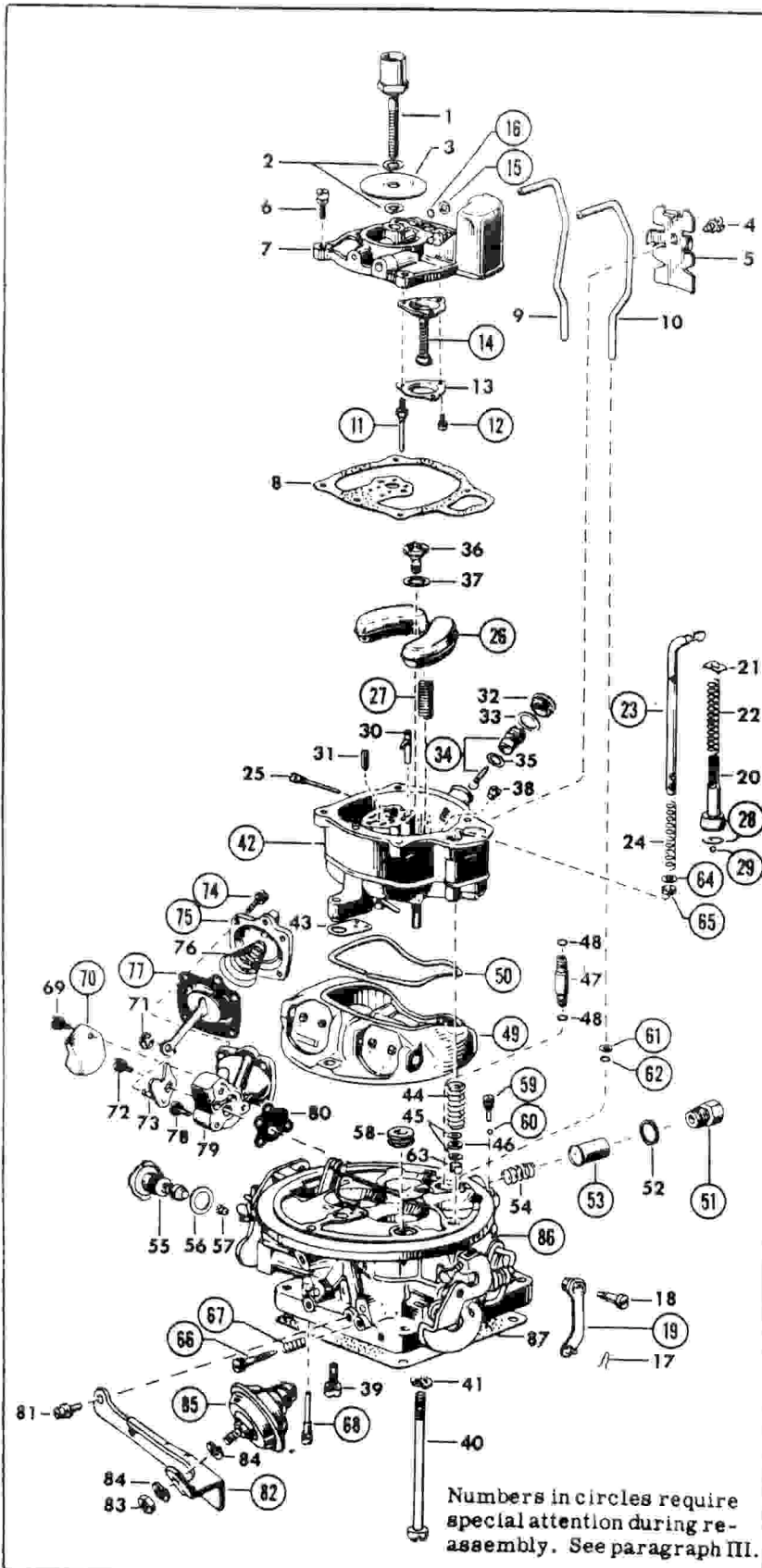

Numbers in circles require special attention during re-assembly. See paragraph III.

- 1 Air cleaner screw
- 2 Lockwashers
- 3 Bleeder screen washer
- 4 Screw and lockwasher assy
- 5 Secondary connecting tube bracket
- 6 Screw and lockwasher assy
- 7 Main body cover assy
- 8 Main body cover gasket
- 9 Secondary connecting tube - LH
- 10 Secondary connecting tube - RH
- 11 Secondary jet assy
- 12 Screw and lockwasher assy
- 13 Economizer body cover clamp
- 14 Economizer diaphragm assy
- 15 Secondary tube seal washer
- 16 "O" ring seal
- 17 Pin spring
- 18 Pump rod stud
- 19 Pump link assy
- 20 Pump plunger assy
- 21 Pump spring washer
- 22 Pump spring
- 23 Pump operating rod
- 24 Pump return spring
- 25 Float pin
- 26 Float assy
- 27 Float spring
- 28 Pump inlet check valve retainer
- 29 Pump inlet check ball
- 30 Discharge nozzle assy
- 31 Pump discharge needle
- 32 Fuel needle valve seat plug
- 33 Fuel needle valve seat plug gasket
- 34 Fuel needle and seat assy
- 35 Fuel needle seal gasket
- 36 Power valve assy
- 37 Power valve gasket
- 38 Main metering jet
- 39 Screw and lockwasher assy
- 40 Throttle body screw - long
- 41 Lockwasher
- 42 Main body assy
- 43 Main body to throttle body gasket
- 44 Pump rod seal spring
- 45 Pump rod seal washer
- 46 Pump rod seal felt
- 47 Fuel inlet fitting
- 48 "O" ring seals
- 49 Air horn assy
- 50 Air horn seal
- 51 Fuel inlet fitting
- 52 Fuel inlet fitting gasket
- 53 Fuel filter screen
- 54 Filter screen retainer spring
- 55 Spark valve assembly
- 56 Spark valve gasket
- 57 Spark valve restriction
- 58 Air tube grommet
- 59 Secondary check ball retainer
- 60 Secondary check ball
- 61 Secondary jet tube seal washer
- 62 "O" ring seal
- 63 Bowl vent selector (on pump rod (23))
- 64 Pump rod lubricator washer
- 65 Pump rod lubricator ring
- 66 Idle adjusting needle
- 67 Idle adjusting needle spring
- 68 Distributor check ball retainer
- 69 Screw and lockwasher assy
- 70 Diaphragm housing cover
- 71 Diaphragm link retainer
- 72 Screw and lockwasher assy
- 73 Diaphragm lever assy
- 74 Screw and lockwasher assy
- 75 Diaphragm cover
- 76 Diaphragm spring
- 77 Diaphragm assy
- 78 Screw and lockwasher assy
- 79 Diaphragm housing assy
- 80 Diaphragm housing gasket
- 81 Screw and lockwasher assy
- 82 Dashpot bracket
- 83 Dashpot attaching nut
- 84 Lockwashers
- 85 Dashpot assy
- 86 Throttle body assy
- 87 Mounting flange gasket

\*Not used on all model carburetors.